



汽车**CAN FD**收发器系列

TJA144x

Last Updated: Apr 20, 2023

TJA144x系列收发器可在控制器局域网(CAN)或CAN灵活数据传输速率(FD)协议控制器和物理双线式CAN总线之间提供接口。

- TJA1441: 基础CAN
- TJA1442: 待机模式CAN
- TJA1443: 休眠模式CAN
- TJA1448: 双通道待机模式 CAN

所有型号在CAN FD快速相位下，即使数据速率高达5 Mbit/s，也能实现可靠的通信。

TJA144x可作为高速经典CAN和CAN FD收发器的简单替代品。它提供引脚兼容性，可避免更改硬件和软件设计，使TJA1442可以轻松地改装为现有应用。

AEC-Q100 0级型号TJR144x可用于高温应用，支持在150°C环境温度下运行。

TJF1441是一种为低速工业解决方案优化的器件版本。

如需了解更多信息和样品供货情况，请联系当地的销售机构。

TJA1441 Block Diagram Block Diagram

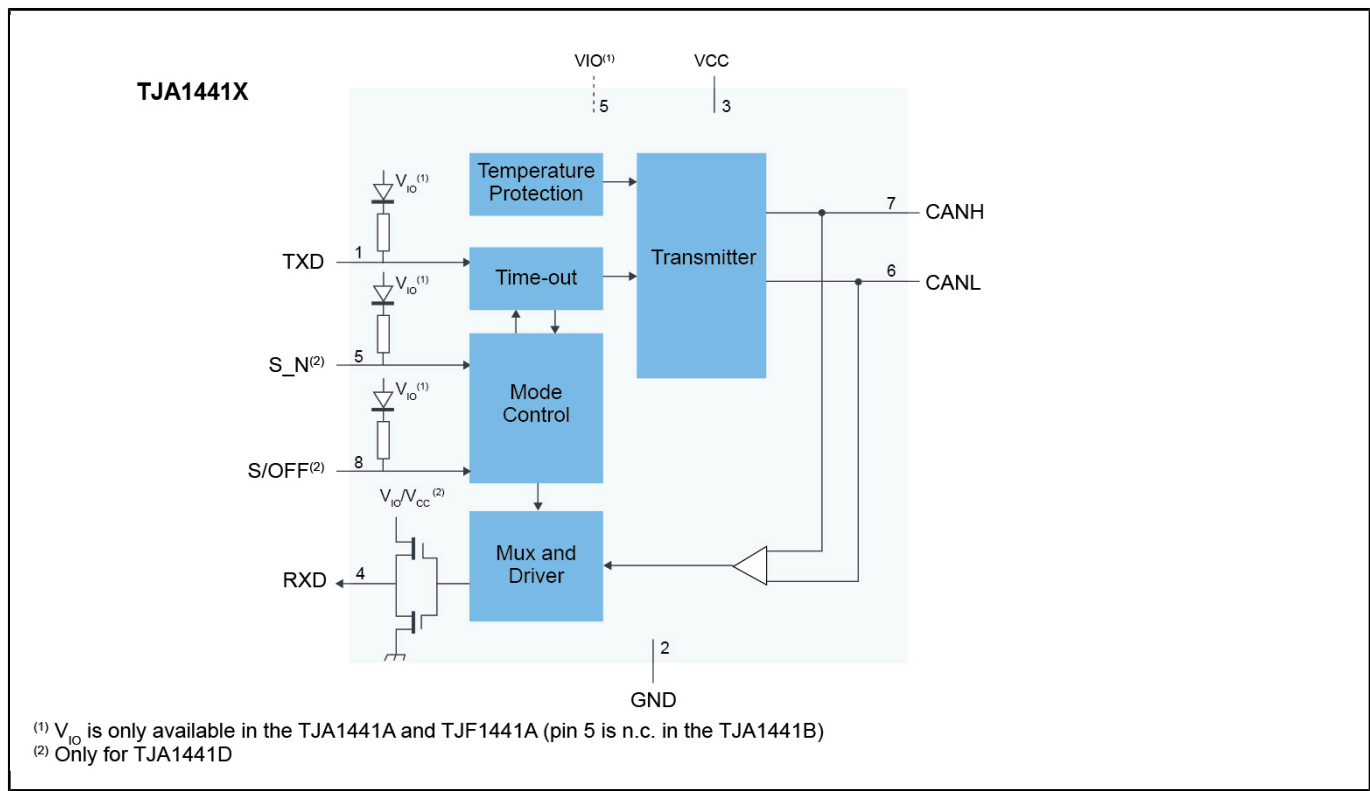

TJA1442 Block Diagram Block Diagram

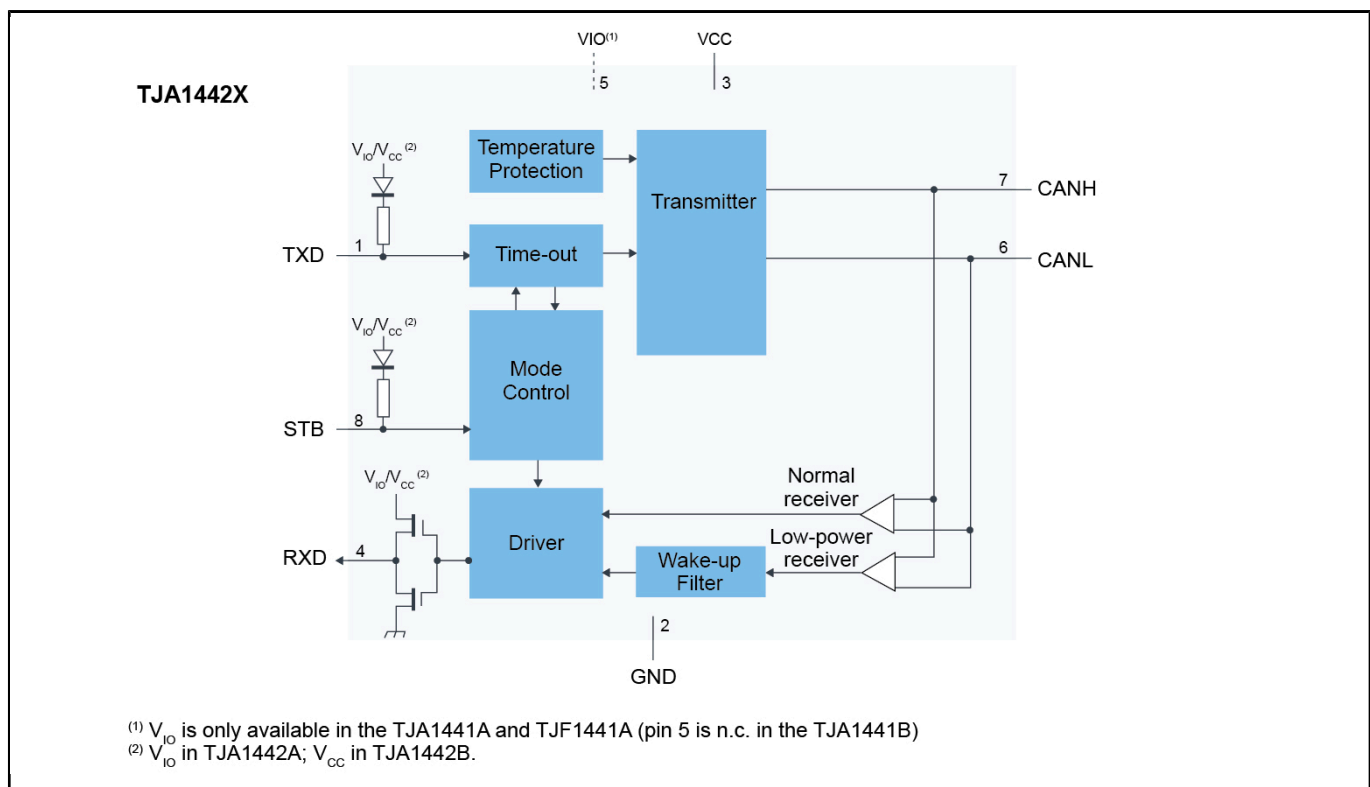

TJA1443 Block Diagram Block Diagram

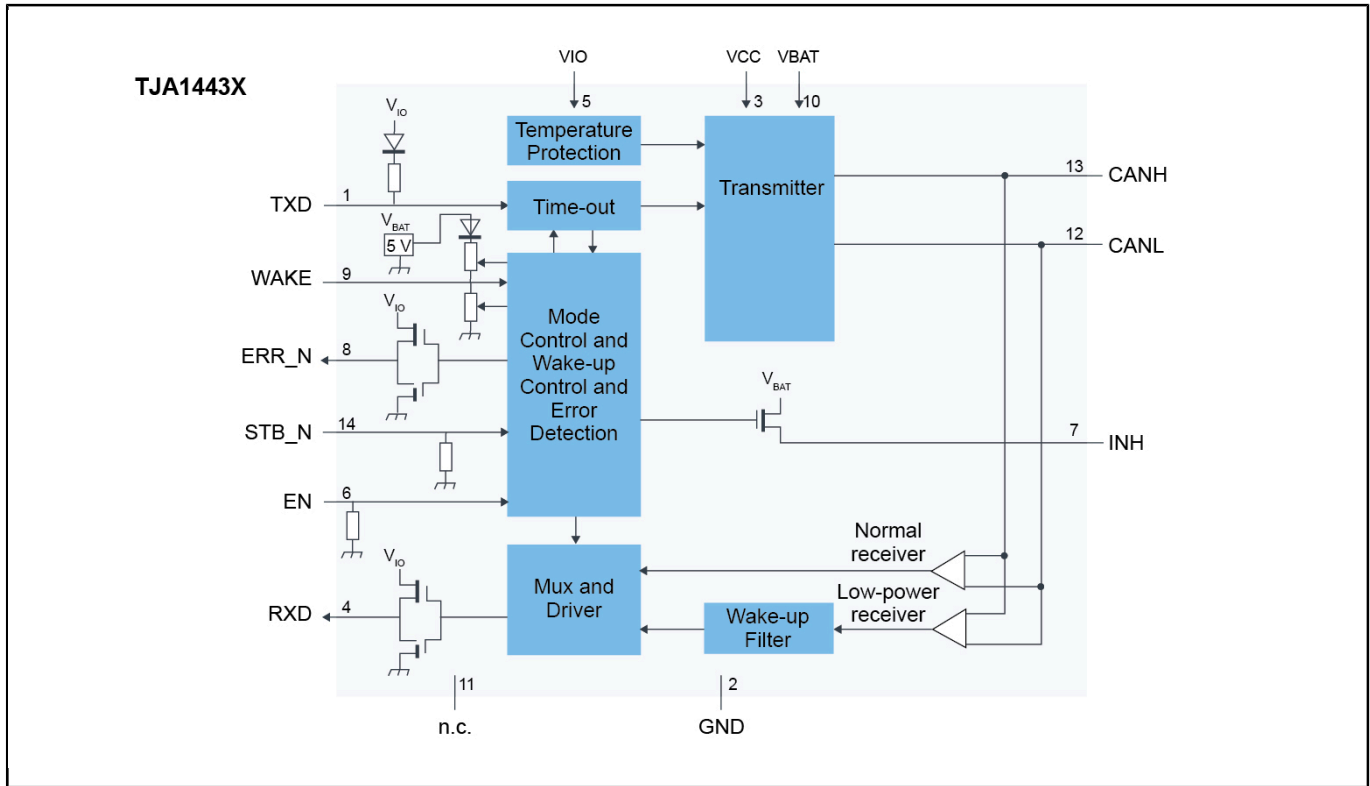

TJA1448 Block Diagram Block Diagram

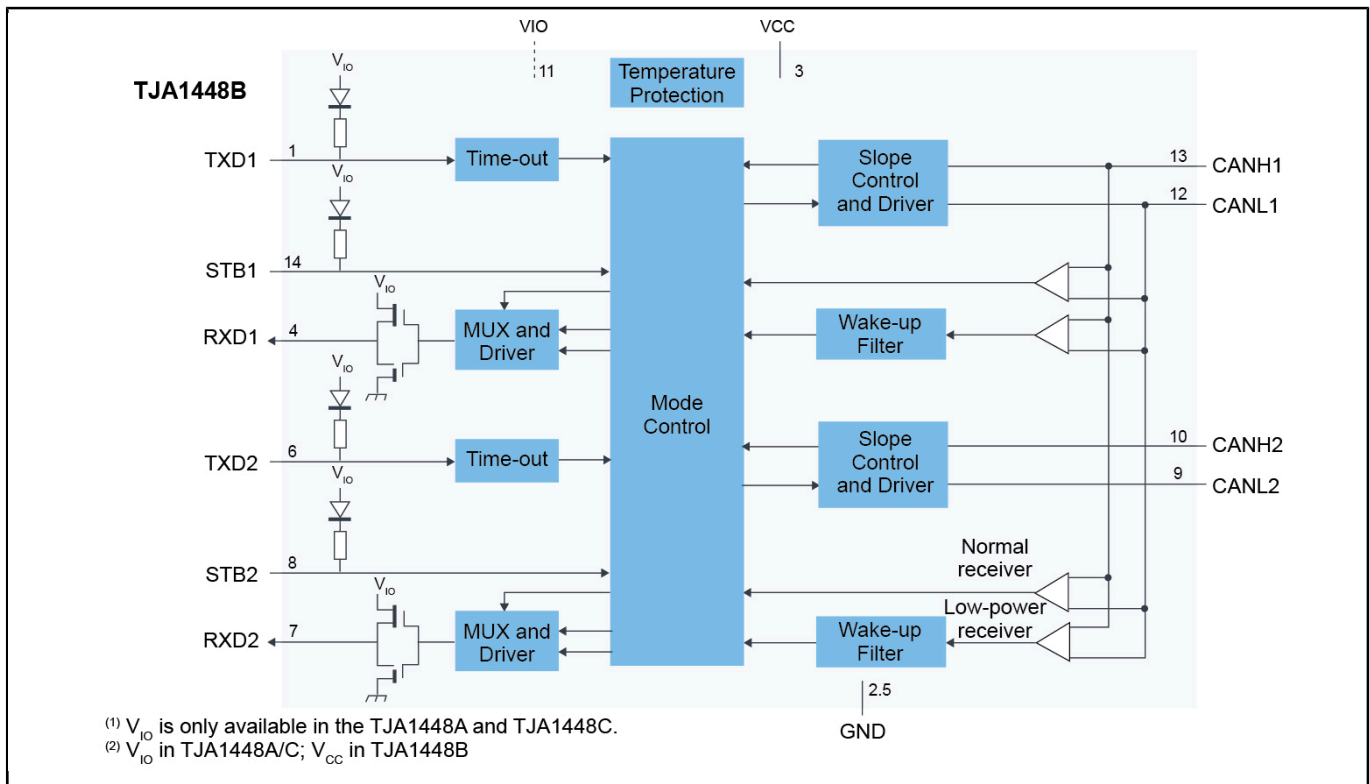

Note: The information on this document is subject to change without notice.

www.nxp.com

NXP and the NXP logo are trademarks of NXP B.V. All other product or service names are the property of their respective owners. The related technology may be protected by any or all of patents, copyrights, designs and trade secrets. All rights reserved. © 2024 NXP B.V.